

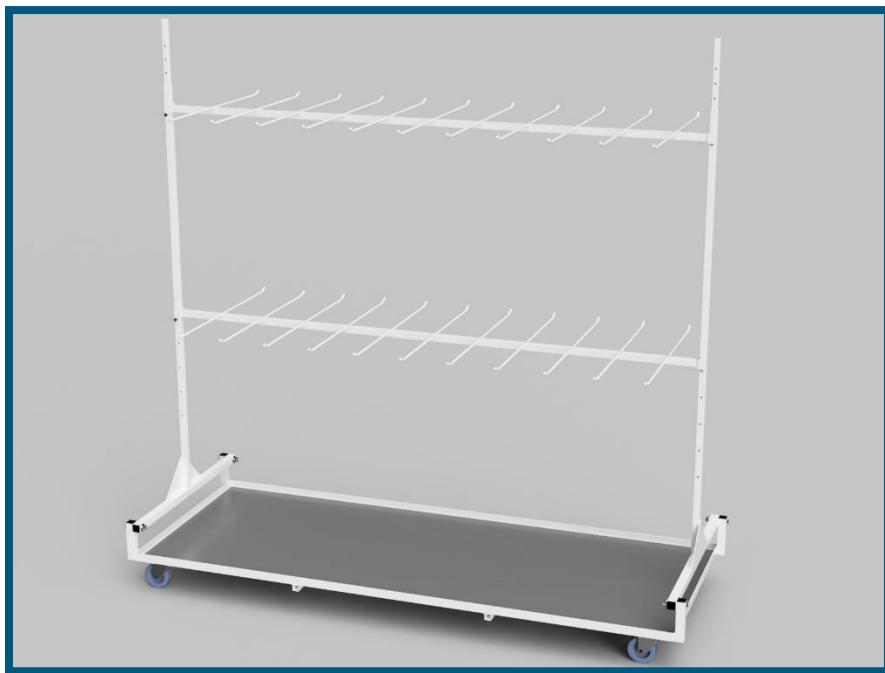



DRY RACK ASSEMBLY INSTALLATION

Complete Instructional Guide





TOOLS NEEDED FOR INSTALLATION

	<p>(2) - 5/8" WRENCH</p>
	<p>TAPE MEASURE</p>

PARTS LIST

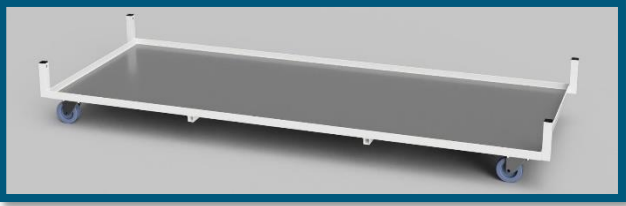
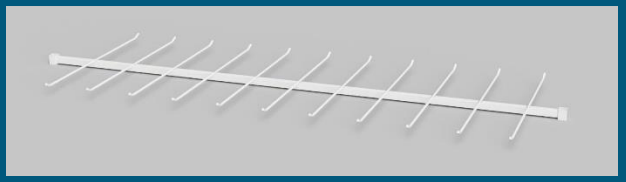
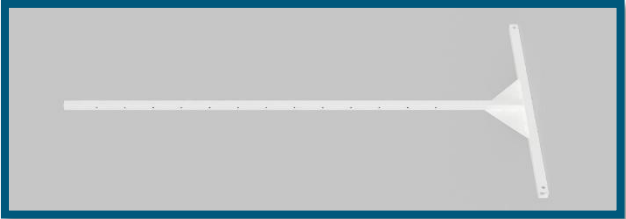
CONFIRM ALL PARTS ARE PRESENT BEFORE STARTING INSTALLATION

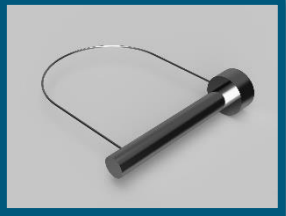
	<p>DRY RACK BASE</p>
	<p>(2) – DRY RACK TIER</p>
	<p>(2) – UPRIGHT POST</p>
	<p>(2) – UPRIGHT EXTENTIONS</p>
	<p>(2) – WIRE SNAP PIN</p>

FOLLOW INSTRUCTIONS BELOW

STEP #1

INSTALLING UPRIGHTS.

- Place first upright on the **Inside** of upright supports on end of base frame, line existing holes up and insert 7/16-14 hardware from outside going in. *Shown Fig. 1a.*
- Repeat same steps for second upright. *Shown Fig. 1b.*

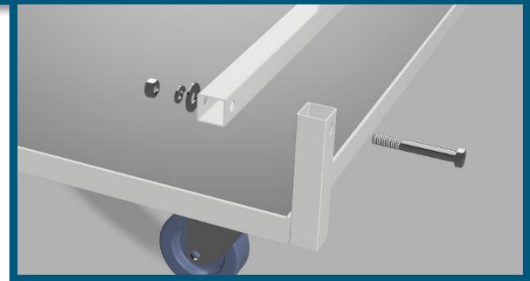
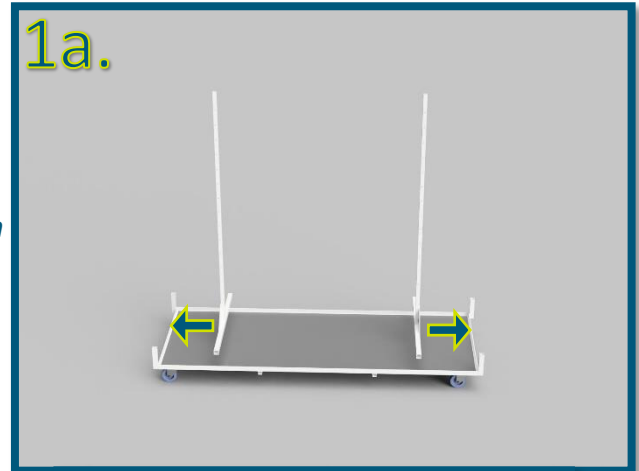
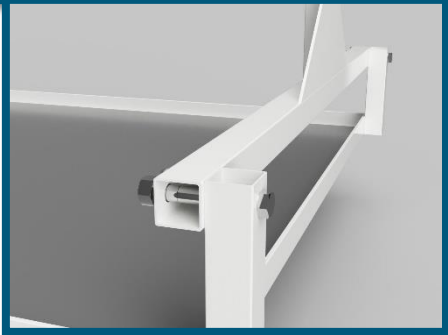
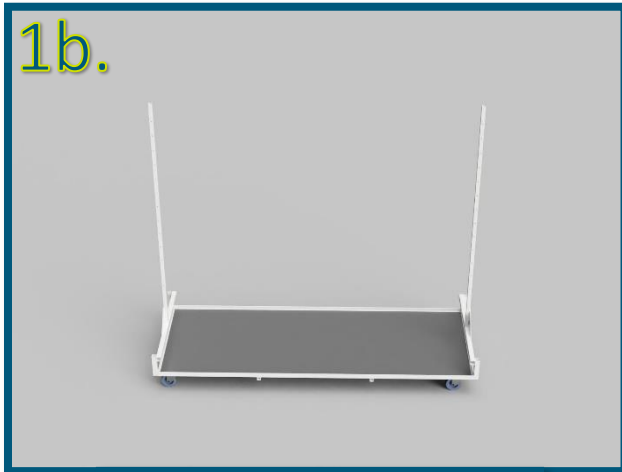

- Tighten hardware down on all 4 corners until split lock washer sits flat.

DRY RACK ASSEMBLY INSTRUCTIONS

STEP# 2

Install Dry Rack Tier

Note: 2 Person Step

Align Dry Rack Tier ends up with installed uprights, lower tier down to desired height. *Shown 2a.*

Note: Make sure Tiers are lowered at a level consistency, if not tier will bind and be put in a stuck position.

Once Tier reaches desired height install Wire Snap Pin in closest hole to the bottom of connection point. *Shown Fig. 2b.*

Repeat same step for 2nd Dry Rack Tier

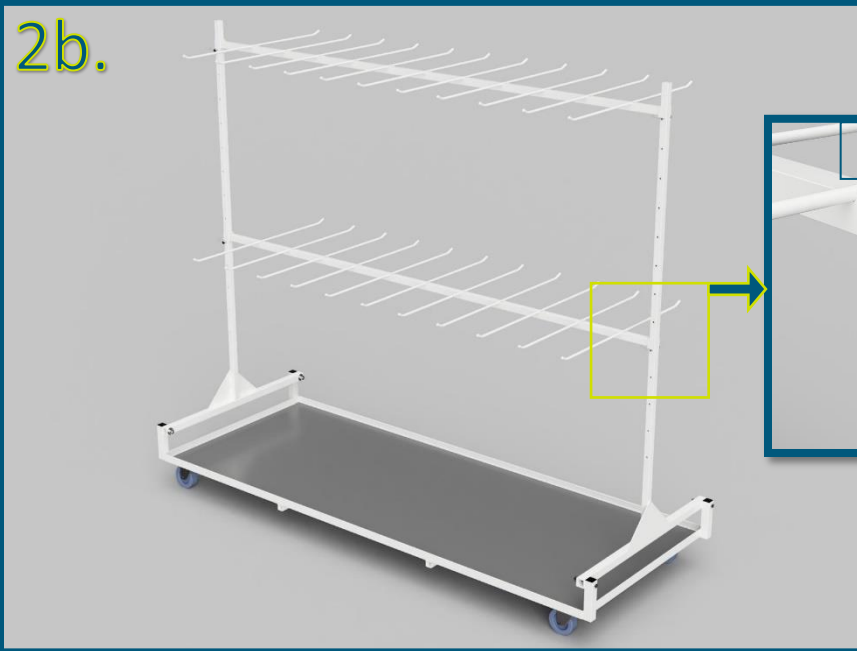
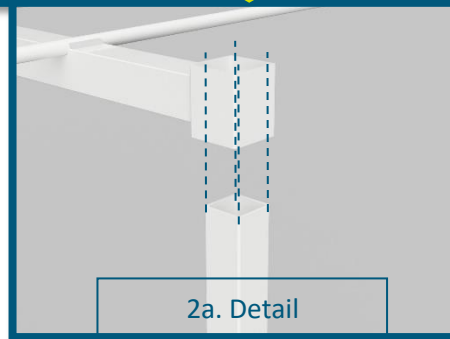
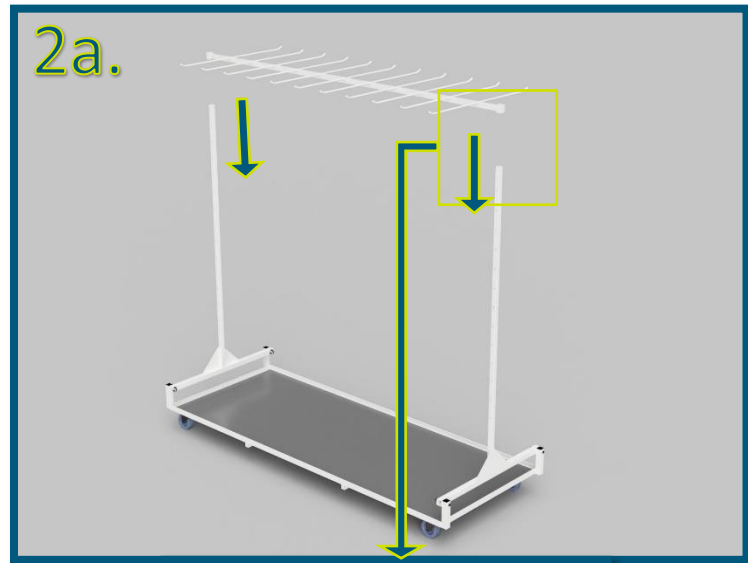

DRY RACK ASSEMBLY INSTRUCTIONS

STEP #3

Installing Dry Rack Tiers W/ Upright Extension

Note: 2 Person Step

If Applicable:

With 1 tier installed, insert Upright Extension in the opening on the top of installed Upright. *Shown Fig. 3a.*

Extensions should slide down to the Snap Wire Pin. Remove pin and raise tier while holding on to extension at desired height so through-holes are aligned. Place pin below tier (same as [step 2b](#)) through aligned holes in Upright and Extension. *Shown Fig 3b.*

2nd Tier will be installed on extension using the same method as [step 2a](#). Additional diagrams showed on [page 7](#).

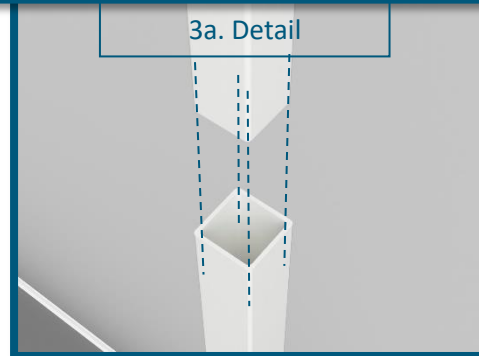
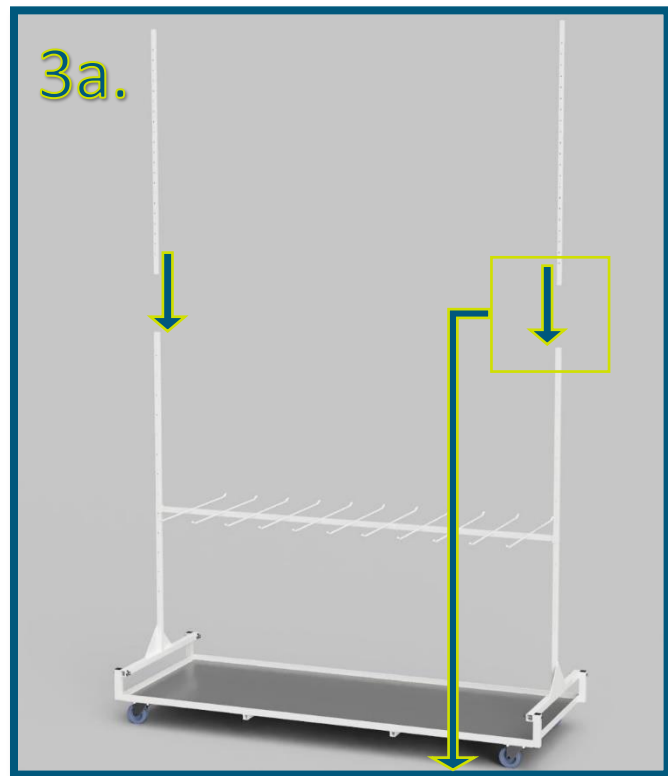

DRY RACK ASSEMBLY INSTRUCTIONS

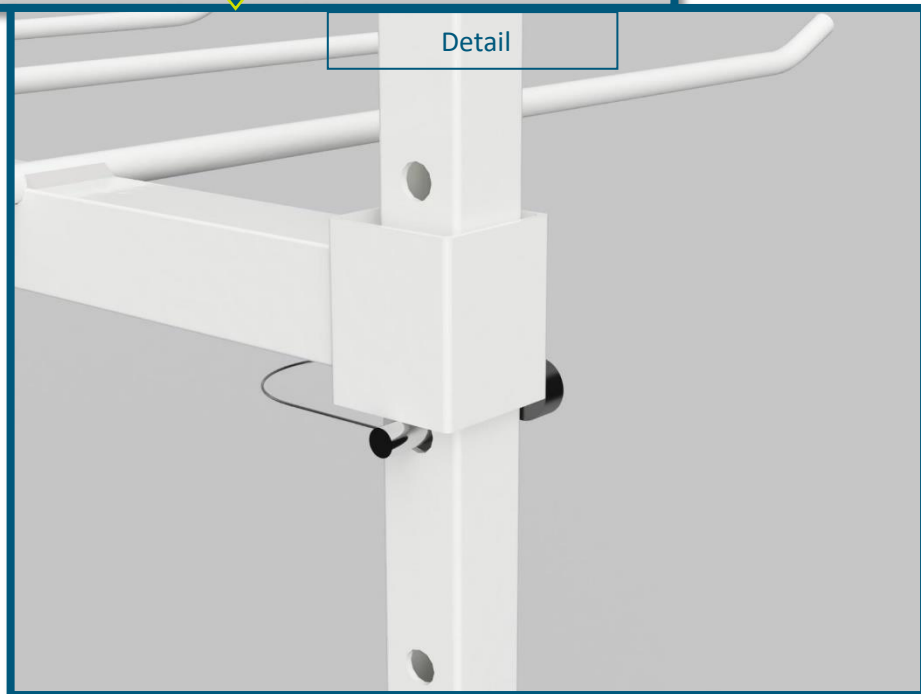
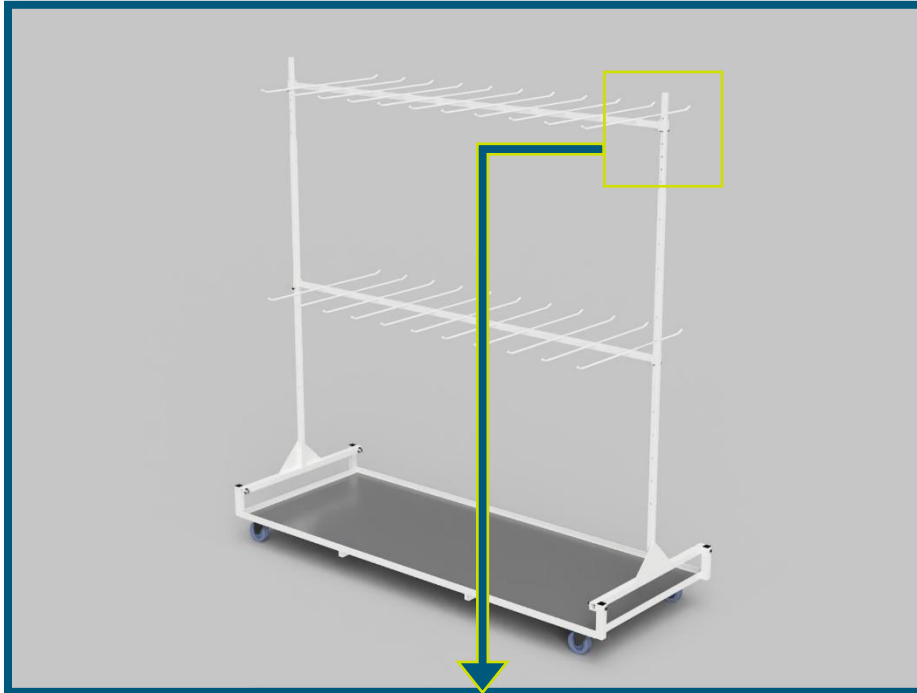



CONGRATULATIONS YOUR DRY RACK UNITS HAVE BEEN ASSEMBLED!

