



INNOVATIVE GROWERS EQUIPMENT INC.

HYDROFARM COMMERCIAL
DIVISION

ASSEMBLY INSTRUCTIONS FOR ARCHIVAL ROLLING BENCHES Complete Instructional Guide



TOOLS NEEDED FOR ASSEMBLY



3/4" & 1/2" WRENCH



3/4" & 1/2" SOCKET
(WE RECOMMEND AN IMPACT GUN FOR LARGER JOBS)



HAMMER DRILL W/ BITS



ASSORTED ALLEN WRENCHES



POWER DRILL
(FOR BENCHES LARGER THAN 5')



TAPE MEASURE



VACUUM (SHOP VAC)



Call 815-991-5010 or email us at sales@innovativegrowersequipment.com if you have any questions

INNOVATIVEGROWERSEQUIPMENT.COM



ASSEMBLY INSTRUCTIONS FOR ARCHIVAL ROLLING BENCHES

FOLLOW INSTRUCTIONS BELOW

STEP #1

Locate the starting point of the track system

Note: you want to be sure the rack will clear any outlets, fans, water supply, etc. on the back wall of the rack.



STEP #2

Place the aluminum base for tracks on the ground and measure the distance from the wall using a chalk line. Make sure it is square on all four sides.



STEP #3

Place 1" steel track into the channel of the aluminum and align the counter sink holes with holes in aluminum.

Note: If the track is longer than 8 ft. 1st aluminum track will be 8 ft, and 1st Insert will be 4 ft so joints are staggered.



Call 815-991-5010 or email us at sales@innovativegrowersequipment.com if you have any questions

INNOVATIVEGROWERSEQUIPMENT.COM

FOLLOW INSTRUCTIONS BELOW (CONT.)

STEP #4

Repeat steps 2 and 3 for the second track and place accordingly (8', 10', 12') for length of benches

Note: Actual length between tracks is slightly more than the nominal length of each section (8', 10', 12'), as the rolling bases are designed so that the legs of the pallet racking for the tiers sit directly over the drive/wheel assemblies. Each upright adds about three inches to the actual length of the rack system. The easiest way to align each additional track is to place one of the base units with the drive wheels on the first track, and the next set of wheels on the next track. If the base is on the stainless-steel tracks and rolls freely, then the track is properly located and can be fastened to the floor.



STEP #5

Drill the first and second hole on the first track that was placed on the ground. Make sure to use a vacuum to clean out the track and drilled holes of dust and concrete after drilling.

Note: Do not place the anchors at this time!

FOLLOW INSTRUCTIONS BELOW (CONT.)

STEP #6

Take the first base section and place it onto the ground beside the tracks that were just drilled. Make sure they are lined up with the steel wheels on the base, and then set into place.

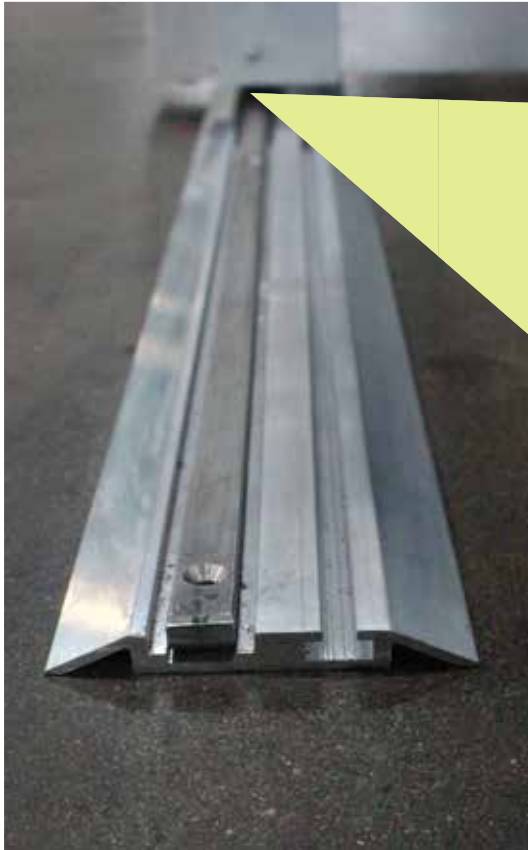

STEP #7

Be sure to note where the gear in on the outside from of the base, as that is the forward control base and should be at the front of the room



FOLLOW INSTRUCTIONS BELOW (CONT.)

STEP #8

Place solid the stainless-steel anti-tip bracket into the base on the inside and set the bolts. A shim is provided to set a base depth of where it should be so it does not ride on the track when moving. Adjustments can be made as needed. This step needs to be taken when every base is set into place.

Note: the anti-tip will be placed on the inside of base and not outside.



STEP #9

To install, drop the end of the anti-tip into the slot on the base track and then rotate 90 degrees to sit flat against the inside of the rolling base next to the wheel. Attach the base side rail with two bolts and nylocks nuts through the pre drilled holes.

Note: small shim in picture below used to install the anti tip so that it does not touch the bottom or top of the slot in the base rail.





ASSEMBLY INSTRUCTIONS FOR ARCHIVAL ROLLING BENCHES

FOLLOW INSTRUCTIONS BELOW (CONT.)

STEP #10

Place the rest of the base on the track and position yourself on the base to allow yourself to roll back and forth on the track, making sure that the tracks are going to align.

Note: Be sure to move slow and also to note on all four wheels, if there are any spots that the track dips as shimming may need to be done to ensure tracks and bases stay into place and don't move.

STEP #11

After moving base back and forth on tracks, making sure alignment is good. Go to the second hole that was drilled, place anchor into concrete with hammer and use impact drill to tighten track to the ground.

STEP #12

Make sure the tracks are also in line with each other from the side by measuring them using the base. Make sure that the base unit rolls freely on both track sections and does not bind up.

STEP #13

When the tracks are lined up, move to the second track that was set down and drill holes into concrete. Make sure to move base close to holes to make sure the alignment to the base and the tracks do not go out of line.

Note: BE SURE TO NOT SET ANCHORS INTO TRACK AT THE ENDS, AS BUMPERS WILL NEED TO BE ADDED.



Call 815-991-5010 or email us at sales@innovativegrowersequipment.com if you have any questions

INNOVATIVEGROWERSEQUIPMENT.COM

FOLLOW INSTRUCTIONS BELOW (CONT.)

STEP #14

When all of the holes have been drilled and cleaned, you can add the bumpers to the edge of the track. Place anchor through bumper, hammer into concrete, and set the screw.

Note: BUMPERS WILL ONLY GO ON VERY ENDS OF THE TRACK TO ENSURE BASES STAY ON TRACK.



STEP #15

Next move to the gear box and mount to the base. Pull the cover off with a hex head (6 screws on sides) and bolt it to the face of base where main driver gear is located.

STEP #16

Fasten the gear box assembly to the base with two stainless steel bolts, washers, and nylocks nuts.

Note: Bolt goes through from inside of assembly, through predrilled holes in base unit. Washers and nylocks nuts go on the inside of the base unit.

STEP #17

Next move to the gear box and mount to the base. Pull the cover off with a hex head (6 screws on sides) and bolt it to the face of base where main driver gear is located.

(see next page)

STEP #18

Once the chain is in place, tension can be adjusted with tensioner located inside of gear box. Chain tension does not need to be set too tight, but enough to make sure there is response between the hand crank and movement of base. *(see next page)*

FOLLOW INSTRUCTIONS BELOW (CONT.)



INSTALLATION OF DRIVE BOX

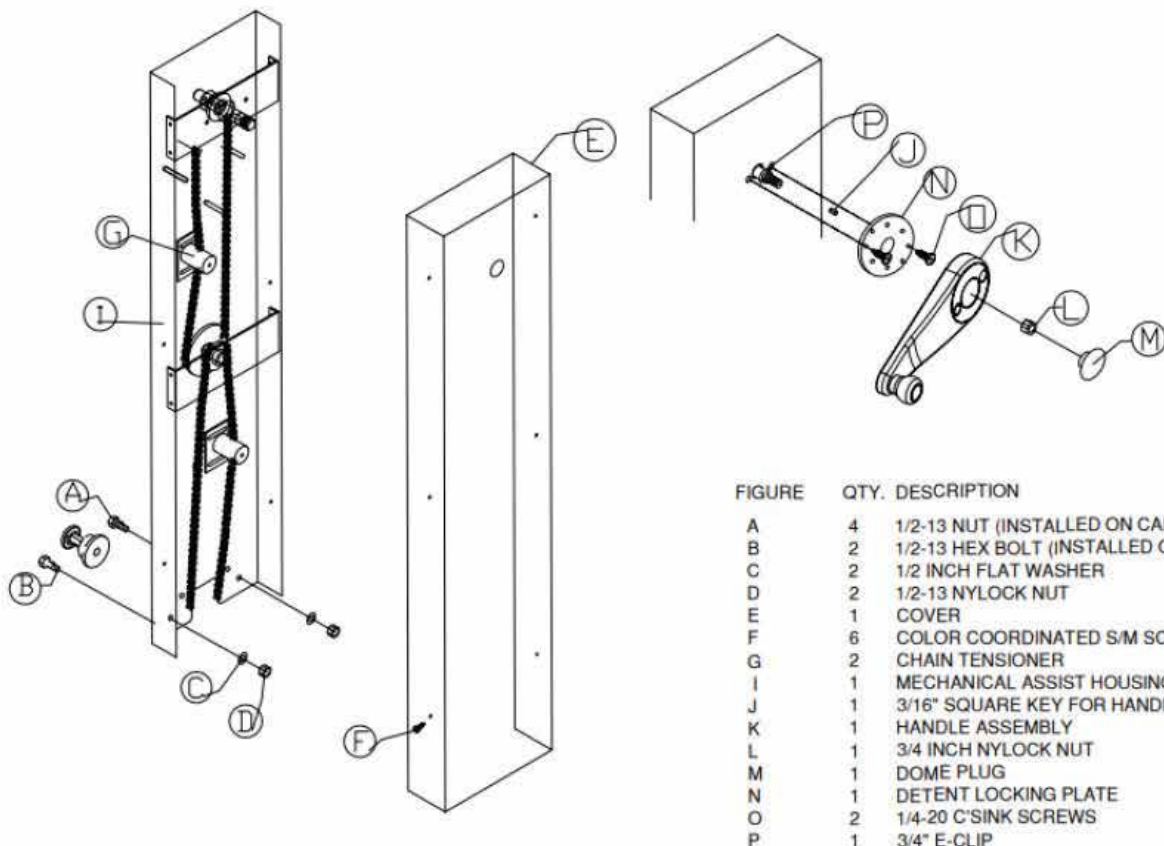

FIGURE	QTY.	DESCRIPTION
A	4	1/2-13 NUT (INSTALLED ON CARRIAGE)
B	2	1/2-13 HEX BOLT (INSTALLED ON CARRIAGE)
C	2	1/2 INCH FLAT WASHER
D	2	1/2-13 NYLOCK NUT
E	1	COVER
F	6	COLOR COORDINATED S/M SCREW
G	2	CHAIN TENSIONER
I	1	MECHANICAL ASSIST HOUSING
J	1	3/16" SQUARE KEY FOR HANDLE
K	1	HANDLE ASSEMBLY
L	1	3/4 INCH NYLOCK NUT
M	1	DOME PLUG
N	1	DETENT LOCKING PLATE
O	2	1/4-20 C'SINK SCREWS
P	1	3/4" E-CLIP

NOTE: OBSERVE THE LOWER CHAIN ROUTING. CHAIN MAY NOT FIT PROPERLY IF ROUTED DIFFERENTLY.

STEP #19

Place the cover back on gear box and base is completed.



FOLLOW INSTRUCTIONS BELOW (CONT.)

STEP #20

These steps will need to be completed for every base being placed on track. If there are any questions about building out base, setting track, or general questions, you can contact our tech support line at 815-991-5010.

STEP #21

If your installation is longer than one section, you will need to repeat most of the above steps to add each “slave unit” to extend the length of your base unit. If you have multiple length units, the two side rails of the first (drive) unit will extend past the back set of wheels, and be pre drilled to attach the next (slave) unit. Each slave unit will be installed similar to the above steps. A piece of matching side rail is furnished with pre drilled holes to attach each slave unit to the previously installed unit, with stainless steel bolts and nylocks nuts. After attaching the slave unit and aligning the next floor track, stainless steel bar, and anchoring to the floor, you will need to install the drive shaft extension to connect the new drive wheel on the slave unit. Slide the drive shaft extension onto one of the drive shafts at a drive wheel all the way, then onto the drive shaft at the other end. Then align the hole in the drive shaft extension with the hole in the drive shaft of the previously installed unit, attaching with stainless steel bolt and nylocks nut. Then align the hole at the other end and fasten in the same way.

Note: you may have to lift this end of the base and rotate the drive wheel to align the hole in the drive shaft with the hole in the extension tube.





SETTING UPRIGHTS, SIDE RAILS, AND BENCH TOPS

STEP #1

Start by taking the uprights and starting at bottom to place side rails at the desired height for the lowest shelf. Set desired height or space between the benches based on number of tiers. Note that the bench top assembly will add a little over 4" to the top of the side rails, and make sure to allow space for lights, ventilation, or other item you may have at each level.

STEP #2

Place all side rails as needed then place racks onto base making sure the base is on locked position to avoid movement.

STEP #3

When rack unit is aligned onto the rolling base unit, it can be attached to the base at each leg with two stainless steel bolts and nylocks nuts.



STEP #4

Once placed on track, optional welded wire for lights can be added on any layer, then bench tops can be added on top of the wire.





SETTING UPRIGHTS, SIDE RAILS, AND BENCH TOPS

STEP #5

When the entire base unit is assembled and the racking, side rails, and optional wire mesh for lights are installed and attached to the base unit, you can assemble the bench top units (following bench assembly instructions included). Each bench top unit will have a bench cross bar near each end with two small stoppers facing downward that will sit just inside the side rails of the racking system. These are to prevent any chance of the benchtops sliding off the racking system. It may be necessary to adjust the wire mesh for light hanging (if you use this option) a little bit one way or the other to let the stoppers sit down between the side rails properly.

STEP #6

Once all bench tops have been added, move rack back and forth to ensure nothing is binding and it is all set properly. If unit does not move very freely back and forth, it may be necessary to loosen the bolts on one or more of the anti-tip bars and re adjust them, as occasionally the added weight of the shelving will cause them to sink slightly and bind up on the aluminum track.

STEP #7

These steps can be repeated for every rack system and be placed onto base.

STEP #8

If your installation involves bench systems that are longer than one unit (Drive unit plus one or more slave units), after the first set of racks is assembled and installed on the base unit, the next unit(s) will need to be assembled on the base unit. This is easy to do. Hold up the leg unit for the next set of racks on the base unit, and install one of the side rails connecting it to the previously installed unit. After one side rail is attached, and locked into place the upright will be supported, and assembly can continue as for the previous unit.

CONGRATULATIONS!
YOU'VE NOW COMPLETED YOUR
ARCHIVE ROLLING BENCH



If you have any questions, or need help, please feel free to contact us:

Innovative Growers Equipment, Inc.
sales@innovativegrowersequipment.com
Phone: 815-991-5010

