

2



1

B

B

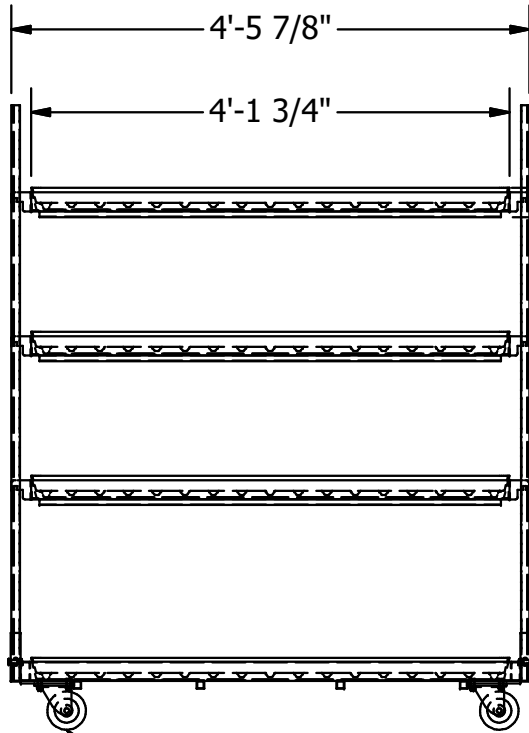

2x Fixed Caster
2x Swivel Caster

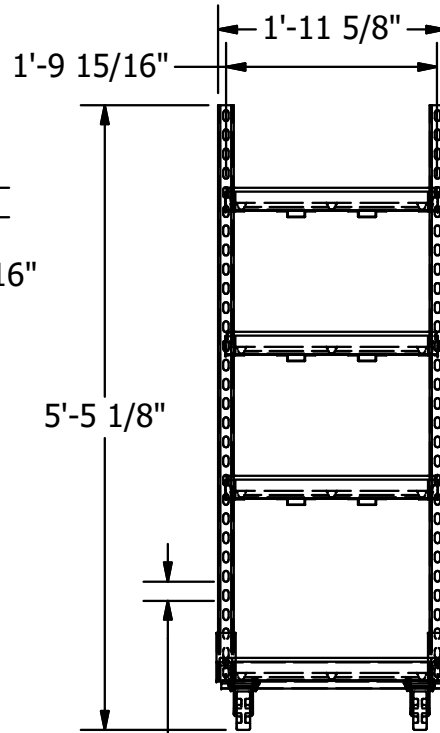

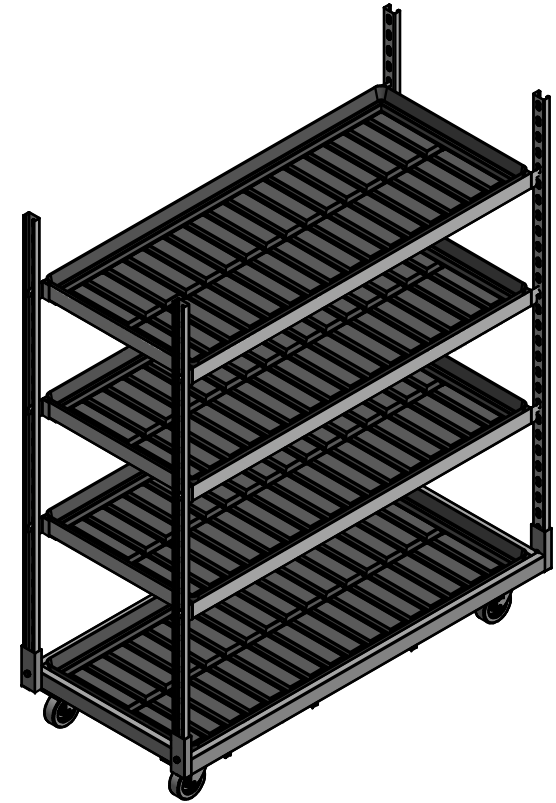

2" TIER ADJUSTABILITY

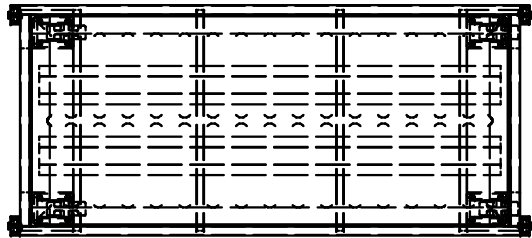

A

A



DRAWN: T.FELTZ		DATE: 6/29/2022		 INNOVATIVE GROWERS EQUIPMENT Address: 421 N. California St Sycamore, IL 60178 (Building 6) Phone: 1-(815)-991-5010 Email: CAD@innovativegrowersequipment.com	
<small>UNLESS OTHERWISE SPECIFIED DIM. ARE IN INCHES TOL. ON LINEAR (DECIMAL) FRACTIONAL X.X ± 0.3 ± 1/16 X.XX ± 0.06 BEND ± 1° X.XXX ± 0.005 RADIUS ± 1/16 TOL. ON ANGLE: ± 0.5° HOLES ± 1/16 INTERPRET DIM. AND TOL. PER ASME Y14.5-2009 DO NOT SCALE DRAWING</small>					
FINAL TOP LEVEL ASSEMBLY PART #:				PART Mobile Clone Cart	
PRECEDING PART #:					
SUCCEEDING PART #:				SIZE DWG NO REV A 95-000 A	
RAW MATERIAL PART #:					
MATERIAL SPEC:				SCALE 1 / 20 SHEET 1 OF 1	
FILE: C:\Users\Public\Documents\Auto desk\Inventor 2023\Templates\en-US\IGE-A.i.dwg					

REV	DATE	AUTHOR	DESCRIPTION
A	6/27/2022	T.FELTZ	Drawing Released

REVISION HISTORY

2



1